

Polaris RZR S Front Fender Flare Kit 62001

Before you begin, read these instructions and check to be sure all parts and tools are accounted for.

Kit Components:

Qty.	Part Description	Tools required for installation:
1	Front Fender Flares (pair)	4mm Allen
10	Pan Head Screw M6x15mm	T-25 Torx
2	Pan Head Screw M6x20mm	1/4" Drill Bit
12	6MM flange nut	3/8" Drill Bit
6	5mm Well Nut	Phillips Screwdriver
6	5mm x 25mm Pan Head Screw	10mm wrench
6	#10 Fender Washer	
12	6mm Flange Nuts	

Fitment: 2009-2014 RZR 800 S & 2010-2014 RZR 4 800

INSTALLATION INSTRUCTIONS – Front Passenger Side

NOTE: Reference illustration for holes and panels. The assembly is in alpha-numeric order.

1. Secure vehicle and turn front wheels all the way to the right.
2. Panel A/Hole 1 utilizes an existing fastener. Remove the bolt using a T-25 Torx driver and install fender flare and lightly tighten. **SEE PHOTO 1**
3. Holding panel A in place, making sure the outer edge of the fender aligns with the raised edge of the fender flare. **SEE PHOTO 2** Mark and drill hole A2 using a 3/8" drill bit. Place well nut into the hole and with a 10-32 pan head screw and washer lightly tighten. **See Well nut diagram.**



4. Holding panel A in place, making sure the edge of the fender lines up with the raised edge of the fender flare. **SEE PHOTO 2** Mark and drill hole A3 using a 1/4" drill bit. Drill all the way through the fender. Install a long pan head screw, making sure the screw head is on the outside of the fender and the flange nut are on the tire side. Lightly tighten.
5. Hold panel B in place, making sure the edge of the fender matches up with the raised edge of the fender flare. Mark and drill hole B4 using a 1/4" drill bit. Insert a short pan head screw and flange nut and lightly tighten.



6. Holding panel B in place, making sure the edge of the fender lines up with the raised edge of the fender flare. Mark and drill hole B5 using a 1/4" drill bit. Insert a short pan head screw and flange nut and lightly tighten.
7. Holding panel B in place, making sure the edge of the fender lines up with the raised edge of the fender flare. Mark and drill hole B6 using a 1/4" drill bit. Insert a short pan head screw with and flange nut and lightly tighten.
8. Panel C gets twisted and installed underneath the side of the RZR on the angled edge. Line the flare up with Mark and drill hole C7 using a 1/4" drill bit. Insert a short pan head screw and flange nut. Lightly tighten.

Polaris RZR S Front Fender Flare Kit 62001

9. Line panel C up with the bottom edge of the angle. Check the topside to make sure the corner appears correct. Mark and drill hole C8 using a 1/4" drill bit. Insert a short pan head screw and flange nut. Lightly tighten.
10. Line panel C up with the bottom edge of the angle. Check the topside to make sure the corner appears correct. Mark and drill hole locations C9 and C10 using a 3/8" drill bit to drill both holes C9 and C10. Remove all sand and debris from the holes.
11. To install well nuts thread 10-32 pan head screw into well nut and use the bolt to push the well nut into holes C9 and C10. Be careful not to push too hard and push the entire well nut into the hole. Once both well nuts are installed remove pan head screws and put the flare back in place insert the 10-32x1 pan head screw and #10 fender washer into holes C9 and C10. Hand tighten with a Phillips screwdriver – do not use a power driver! Reference **Well nut diagram above.**
12. Make sure the fender flare is completely lined up and tighten all fasteners
13. Repeat these instructions for the opposite side.

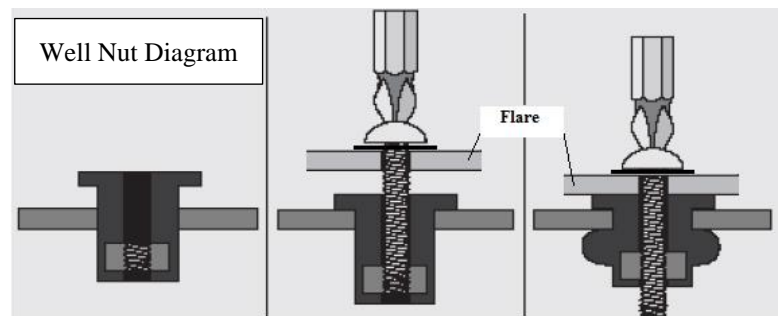

1. Place Well-Nut insert all the way into pre-drilled hole until flange is firmly against mounting surface.

2. Pass machine screw through part to be fastened.

3. Tighten until snug. Do not over tighten. The rubber will crack.

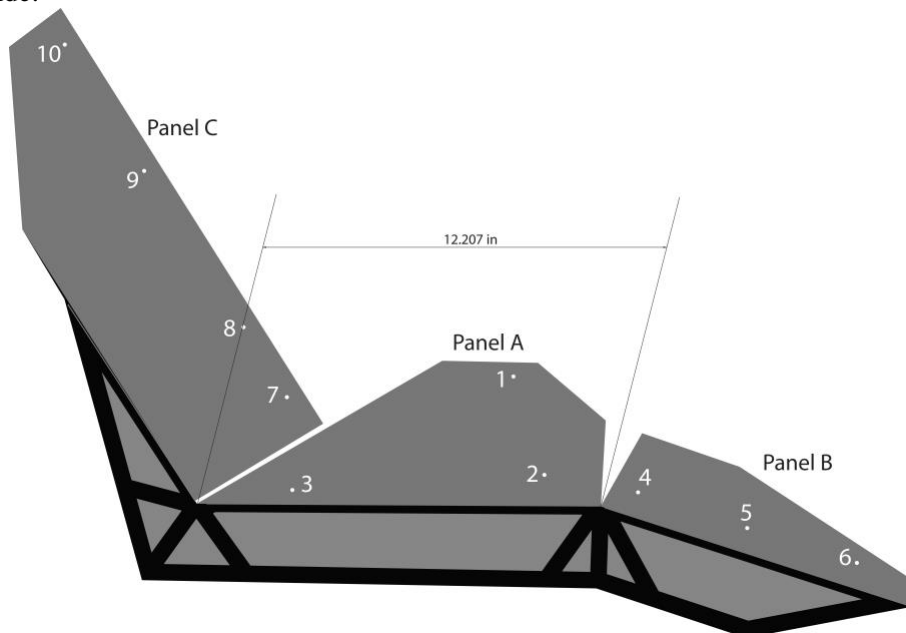

LIMITED WARRANTY

PowerMadd guarantees its products against defects in material and workmanship for a period of twelve (12) months from the original date of purchase. **POWERMADD** shall not be liable for damage or injury caused by defective materials or workmanship. **POWERMADD** may elect to repair or replace this product but is the sole judge of any defects in their product. This warranty does not cover any labor costs to remove or reinstall this product and is effect for one year from the original purchase date.