



Sentinel Handguard Mounting Kit for ATVs & Motorcycles Installation Instructions for Part No. 34452

HARDWARE INCLUDED:

Qty	Description
2	Aluminum Brackets
2	Steel Straps
2	M6 x 75mm Hex Head Bolts
2	M6 x 25mm Hex Head Bolts
2	M6 Lock Nuts
2	M5 x 10mm Button Head Screw
4	Large spacers
2	Flat washers
4	Small Spacers



TOOLS REQUIRED:

- 3mm Hex Wrench
- 10mm Wrench

READ ALL INSTRUCTIONS CAREFULLY PRIOR TO INSTALLATION!

Note: For this mount kit to work on the '07-Current Grizzly & Kodiak, you will need to completely remove the welded tab from the right side of the bars located between the throttle block and brake perch as well as breaking off a section of the welded tab located on the left side of the bars between the brake perch and the control pod. Go online to page two of - www.powermadd.com/products/Handguards/sentinel/instructions/Yamaha_Grizzly_mount.pdf for more information.

PowerMadd's ATV/MX kit comes with two aluminum brackets which can be positioned to mount over the top or underneath the levers. To mount the guards, you will need to find ½" of space on the bar as close to the handgrip as possible. You may need to move your levers, throttle blocks, etc. in order to make room for the mounting bracket.

The photos shown are of an ATV installation. This is due to the fact that ATVs tend to have more controls attached to the bar, making installation a bit more challenging. The same steps apply to motorcycles.

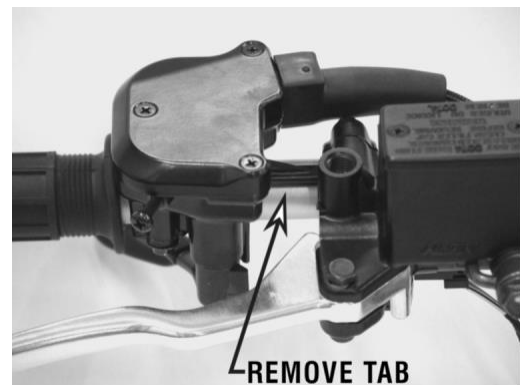

Photo 1 - front view of ATV throttle

RIGHT / THROTTLE SIDE BRACKET

NOTE: Many ATVs and motorcycles have a tab that protrudes from the throttle assembly which spaces the brake perch an exact distance from the throttle (Photo 1). This is to speed up assembly at the factory and can be removed. If you don't want to remove the tab, you can slide the brake lever perch over or mount the handguard bracket on the inside of the brake perch. Once you have found the optimal location to mount the bracket, proceed to step 1.

STEP 1: Slide one of the steel straps onto the handlebar making sure no wires get pinched.

STEP 2: Attach the bracket to the strap by inserting the short M5 button head screw and tighten it with a 3mm hex wrench.

STEP 3: Insert the M6 x 25mm hex head bolt with flat washer through the bracket and thread into the strap. This adjustment bolt is used to achieve the desired tightness of the mount. For now, leave the bracket loose so you can adjust the position up or down after attaching the handguard to the bracket.

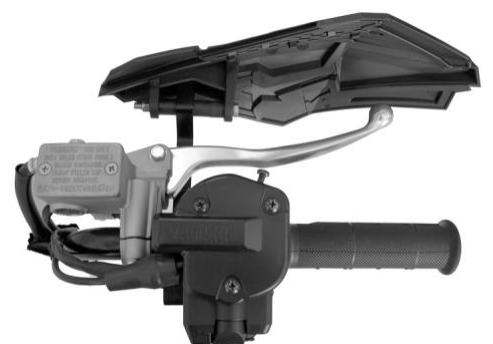

Bracket is positioned under the lever.



Bracket is positioned over lever.

LEFT / CLUTCH SIDE BRACKET

NOTE: On most ATVs you will have to move the clutch (or brake) perch over to create a gap between the perch and grip/control assembly to mount the bracket. On some models the bracket may work on the other side of the perch.

STEP 4: Slide the other steel strap on to the handlebar in between the clutch perch and the grip. Any wires should go outside the strap and bracket.

STEP 5: Attach the brake side bracket to the strap the same as in STEPS 2 & 3.



Right side view of ATV - bracket is positioned under brake lever and angles toward center.

HANDGUARD MOUNTING

STEP 6: The handguard mounts onto the bracket as shown in the photos below. Hold the handguard up to the mounting bracket and determine the optimal location. The optimal location is a personal preference. For the best hand coverage, the end of the handguard should extend beyond the handle bar about 1". Once you have determined the location of the mounting bracket within the handguard mounting tabs, slide the M6 x 75mm Hex Head Bolt through one mounting tab and use the available large and small spacers to position the bracket in the desired location (All spacers need to be used). There are 9 possible positions available. Repeat step 6 for both sides.



STEP 7: At this time go back and check the torque of all fasteners. All fasteners may need to be retightened after the first ride. Check the tightness of the bracket and handguard before each ride.

LIMITED WARRANTY

POWERMADD warrants this product to be free from defects in material and workmanship under use for the purpose it was intended. **POWERMADD** shall not be liable for damage or injury caused by defective materials or workmanship. **POWERMADD** may elect to repair or replace this product, but is the sole judge of any defects in their product. This warranty does not cover any labor costs to remove or reinstall this product and is effect for one year from the original purchase date.